

Grain Milling Plant 85 TPD

PK-5106



Agrex grain milling plant rated at 125 bu/hr (85 tons/day)

Capabilities: Corn, Wheat, Barley, Oats, Rye, Soybeans, Grain Sorghum - was milling corn for an ethanol plant. Plant is fully automated using Allen Bradley PanelView Plus 1250 controls, 480v 3/60. Built in 2008 and ran through mid 2010 then idled. Stored in a protected warehouse. This plant occupies an area approx 55 ft x 22.5 ft and tallest piece (hopper) is 15 ft. Sold as a complete milling system.



Facts At A Glance

Nameplate capacity

- 125 bu/hr (85 TPD)
- Built 2008 Idled 2010

Type of Plant

- Agrex S.p.A. Model AGS4/3500 GR-1SE/24
- Continuous design

Type of Grain:

- Corn, wheat, oats, rye, soybean, grain sorghum

Area

- Approx 55 ft x 22.5 ft and tallest piece (hopper) is 15 ft

Controls & Electrical

- Allen Bradley PanelView 1250
- Electrical 480v 3/60 320A

Hours Run

- Condition Excellent, Less than 1000 hours

Grain Milling Plant 85 TPD

PK-5106



PK-5106
Grain Milling Plant

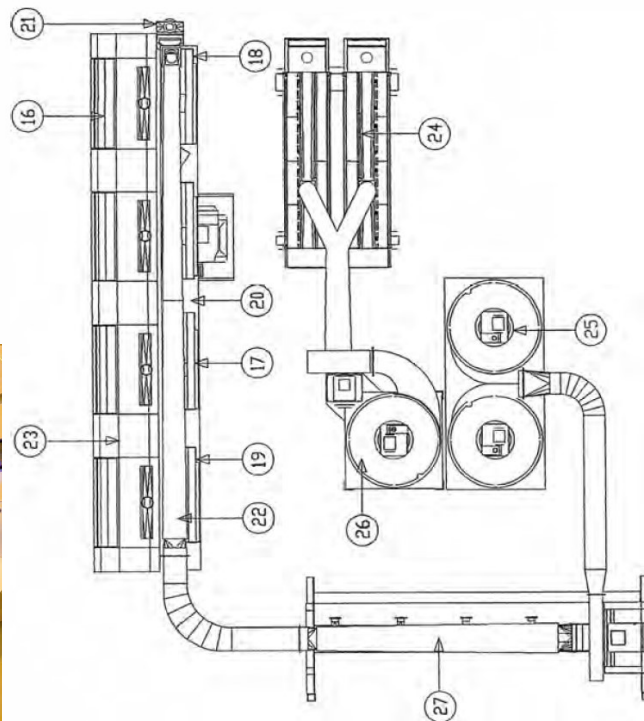
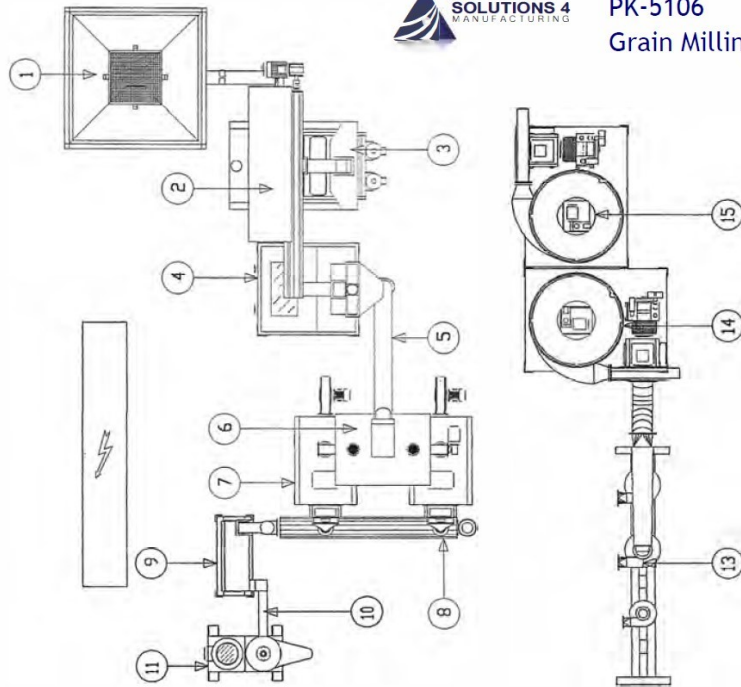

Terms: All equipment is sold As Is Where Is, Subject to prior sale and availability. All quotes are in US Dollars unless specifically noted otherwise. Description of the equipment - especially those relating to capacity, size, or condition - are stated as clearly as possible for information to the buyer or observer. The descriptions and representations cannot be taken as accurate. The buyer has the sole responsibility to determine size, capacity, capability, suitability, condition, or any other attribute pertaining to the piece of equipment represented or purchased. The assets are sold "As Is", "Where Is" and "with all faults" and except as explicitly stated in the Contract for Purchase. All warranties, including, without limitation, the warranties of merchantability, quality, and fitness for a particular purpose are hereby expressly excluded. Seller makes no representations or warranties as to design, condition, capacity, performance, or any other aspect of the asset.