

06018  
CENTRAL ILLINOIS  
ETHANOL PLANT  
CANTON, ILLINOIS

**CROSS REFERENCE FILE FORM**

EQUIPMENT TAG NUMBER:	PC-4105
INFORMATION/DRAWINGS FILED WITH TAG NUMBER:	PC-2101



Goulds Pumps

# SUPPLIER DOCUMENTS INDEX

TO: LURGI PSI INC  
 ATTN: JADWIGA MILLER  
 1790 KIRBY PARKWAY  
 MEMPHIS, TN 38138

SERIAL NO.: 729P510  
 CUSTOMER: LURGI PSI INC / ORDER: 566323  
 P.O. NO.: 6018-70901  
 PUMP ITEM NO.: PC-4105  
 SERVICES: BRER COLUMN PRED PUMP  
 END USER: CENTRAL ILLINOIS ENERGY, L.L.C.  
 PROJECT #: 2003-01  
 LOCATION: CANTON, ILLINOIS

SUPPLIER INFORMATION: GOULDS PUMPS, INC.  
 240 FALL STREET  
 SENECA FALLS, NY, 13148  
 CONTRACT ADMINISTRATOR: Carl Saugliacomo  
 CONTRACT MANAGER: Dave Spruill  
 DATE: 1/05/07  
 MAILED VIA:

SUPPLIER DOCUMENT TITLE	SUPPLIER DOC.# / REVISION NO.	REVIEW QTY.	FINNL QTY.	DATE APPROVED	SUB#	DOB DATE	SUBMIT DATE	RETURN DATE	REF. CODE
Pump Documents Required Pump Outline			6P	0/00/00	01	12/06/06	12/06/06	0/00/00	
Tapped Openings			6P	0/00/00	01	12/06/06	12/06/06	0/00/00	
Pump CDS Curve			6P	0/00/00	01	12/06/06	12/06/06	0/00/00	
Cross Sectional			6P	0/00/00	01	12/06/06	12/06/06	0/00/00	
3196 Pump Instruction Manuals			6P	0/00/00	01	12/06/06	12/06/06	0/00/00	
Plan 53 With Pinned Tubing			6P	0/00/00	01	12/06/06	12/06/06	0/00/00	
Seal Documents Required Seal Drawing			6P	0/00/00	01	12/06/06	12/06/06	0/00/00	
Motor Documents Required Motor Outline			6P	0/00/00	01	12/06/06	12/06/06	0/00/00	
Motor Wiring Diagram			6P	0/00/00	01	12/06/06	12/06/06	0/00/00	
Motor Electrical/Performance			6P	0/00/00	01	12/06/06	12/06/06	0/00/00	
Motor Instructions-(Reliance)			6P	0/00/00	01	12/06/06	12/06/06	0/00/00	
O.A. Documents Required Comp. Hydrostatic Test Report			6P	0/00/00	01	12/06/06	12/06/06	0/00/00	
Tank Data Required * Tank Drawing			6P	0/00/00	01	12/06/06	1/05/07	0/00/00	

FIELD FILE

06010

\*\*\* End of Report \*\*\*

(\*) Denotes Documents in this Submittal.  
 Your complete Approval is required before order is scheduled and released to manufacturing. Please forward Approval by / /

\*\* The above literature is for your information and records. It does not require your approval. Retain literature as your final distribution.

Note: Any Changes may affect Quoted Price and Shipping Details.

RECEIVED JAN 10 2007

CIE: ETHANOL  
Canton, Illinois

17.1  
PC-4105

01800013048

**BILL OF MATERIALS**

ITEM QTY	DESCRIPTION	PART NO.	MATERIAL
1	SHELL 6" SCH 10 x 26 1/2" LG ERW	401-1187	SA-312 316L
2	TOP HEAD: 6" FOR SCH 10	L30-1107-201	SA-240 316L
3	BOTTOM HEAD: 6" FOR SCH 10	L30-1107-101	SA-240 316L
4	LEVEL GAUGE: LENDO BULLSEYE	LU-0088-101	316 WTD
5	HALF COUPLING: 1/2" NPT CLASS 3000	L10-4387-NP1	SA-182 F316L
6	JOL. NAME PLATE:	L35-0004-005	304 SS
7	1 ITEM: 1/2" NPT GLASS 3000	L10-4317-NP1	SA-182 F316L
8	1 PIPE: 1/2" NPT x 3" LG SCH 160	L13-4417-304	SA-312 316L
9	1 PIPE: 1/2" NPT x 4" LG SCH 160	L13-4417-404	SA-312 316L
10	1 BALL VALVE: 1/2" NPT (2 PCEs)	VB-4486-105	316 SS
11	1 PRESSURE GAUGE: 2 1/2" DIA. 0-200 PSI	PG-4493-002	316 WTD
12	1 FUSE: 1" NPT ROUND BAR	L10-6087-NP1	SA-182 F316L
13	2 BUSHINGS: 1/2" NPT x 1/2" FHT HEX HEAD	L12-4407-2N1	SA-182 F316L
14	1 PIPE: 1/2" NPT x 1 1/2" LG SCH 40	L13-2486-246	SA-312 316L
15	1 PRESSURE REGULATOR: PARKER NO. 20R113C1W	PR-1258-000	BRASS

**John Crane Lemco**  
 400 PSI @ 700 °F  
 AUTOMATIC MONITORING PRESSURE  
 -20" H<sub>2</sub>O @ 400 PSI  
 MONITOR SECTION WITH TRANSDUCER  
 SEE TABLE  
 P/N: 38852-001  
 U.S. S.N. 38852-001  
 NPT NUMBER 38852-001

U.S. S.N.
38852-1
38852-2
38852-3
38852-4
38852-5

**NOTES:**

1. PRESSURE RELIEF DEVICES ARE NOT PROVIDED BY THE MANUFACTURER. (SEE THE ASME CODE SECTION VIII, DIVISION 1, PARAGRAPH UC-125 FOR USER RESPONSIBILITIES).
2. THE WELD JOINT PREPARATION FOR THE BOTTOM HEAD SHALL BE EXAMINED BEFORE WELDING BY PT OR MT PER UC-93(4)(3)(K)(4).
3. AFTER WELDING, BOTH THE PERIPHERAL EDGE OF THE BOTTOM HEAD AND ANY REMAINING EXPOSED SURFACE OF THE WELD JOINT PREPARATION SHALL BE REFINISHED BY PT OR MT PER UC-93(4)(3)(K)(4).

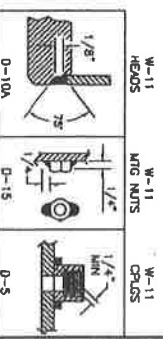
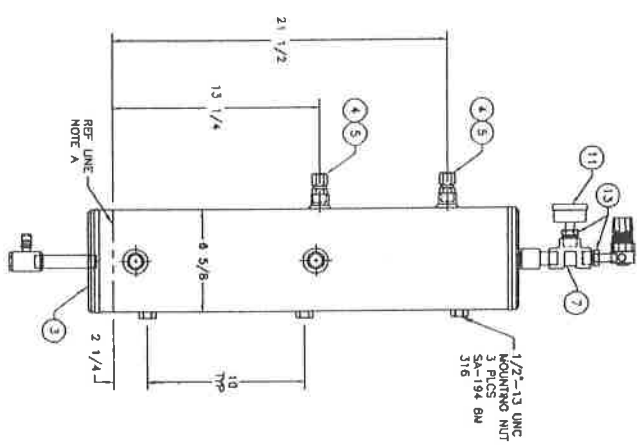
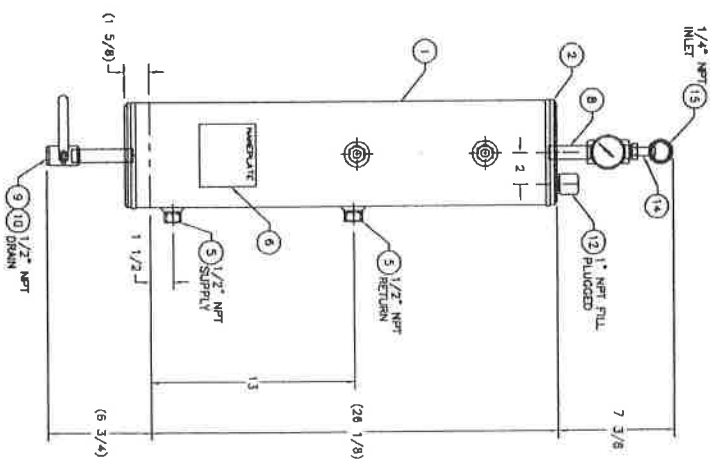

**ASSEMBLY TOLERANCES**  
 (UNLESS OTHERWISE NOTED)  
 GENERAL VESSEL ± 1/4"  
 PIPING STRONG ± 1/2"  
 REF. DIMS ± 1/2"  
 ANGULAR ± 2 DEG

ITEM	DESCRIPTION	QTY	UNIT
1	SHELL	1	PC
2	TOP HEAD	1	PC
3	BOTTOM HEAD	1	PC
4	LEVEL GAUGE	1	PC
5	HALF COUPLING	2	PC
6	JOL. NAME PLATE	1	PC
7	ITEM: 1/2" NPT GLASS	1	PC
8	PIPE: 1/2" NPT x 3" LG	1	PC
9	PIPE: 1/2" NPT x 4" LG	1	PC
10	BALL VALVE	2	PC
11	PRESSURE GAUGE	1	PC
12	FUSE	1	PC
13	BUSHINGS	2	PC
14	PIPE: 1/2" NPT x 1 1/2" LG	1	PC
15	PRESSURE REGULATOR	1	PC

**John Crane**  
 Seed Support Systems

**John Crane Lemco**  
 2831 East Apollo Street  
 Tulsa, Oklahoma 74110  
 Telephone: 918 835 7325  
 Facsimile: 918 835 5033

**RE-1603 3 GAL. RES ASSY**  
**GOULDS PUMPS**  
 CUST. P.O. NO.: 436314  
 P/N: 38852-001  
**INS3-38852-001**

- SHOE NOTES:**
1. REFERENCE LINE IS 1.00" FROM END OF SHELL.
  2. ALL DIMENSIONS IN ( ) ARE REFERENCE DIMENSIONS.
  3. ALL DIMENSIONS ARE IN INCHES.
  4. DRILL HOLES IN SHELL PER LES-2003 UNLESS OTHERWISE NOTED.
  5. LEAK TEST @ 90 PSI.

Customer: LUBRIC PSI, INC.  
 Goulds Serial No: 729F510  
 Customer P.O. No: 6018-70901  
 Item No: PC-4105  
 Service: BEER COLUMN FEED PUMP  
 End User: CENTRAL ILLINOIS ENERGY LLC  
 Project No: 2809-01  
 Location: CANTON, ILLINOIS



# SUPPLIER DOCUMENTS INDEX

## FIELD FILE

TO: LURGI PSI INC  
 ATTN: JADWIGA MILLER  
 1790 KIRBY PARKWAY  
 MEMPHIS, TN 38138

CC: KELLY GURENS  
 LISA COMPTON

SERIAL NO.: 723P510  
 CUSTOMER: LURGI PSI INC  
 P.O. NO.: 6018-70901 / ORDER: 566323  
 PUMP ITEM NO.: PC-4105  
 SERVICE: BEER COLUMN FEED PUMP  
 END USER : CENTRAL ILLINOIS ENERGY, L.L.C.  
 PROJECT # : 2003-01  
 LOCATION : CANTON, ILLINOIS

SUPPLIER INFORMATION : GOLDIS PUMPS, INC.  
 240 FALL STREET  
 SENECA FALLS, NY, 13148

CONTRACT ADMINISTRATOR: Carl Saugiacomo  
 CONTRACT MANAGER: Dave Spruill  
 DATE: 12/06/06  
 MAILED VIA: ups ground

SUPPLIER DOCUMENT TITLE	SUPPLIER DOC.# / REVISION NO.	REVIEW QTY.	FINAL QTY.	DATE APPROVED	SUB#	DTE DATE	SUBMIT DATE	RETURN DATE	RPT. CODE
Pump Documents Required									
* Pump Outline			GP	0/00/00	01	12/06/06	12/06/06	0/00/00	
* Tapped Openings			GP	0/00/00	01	12/06/06	12/06/06	0/00/00	
* Pump CDS Curve			GP	0/00/00	01	12/06/06	12/06/06	0/00/00	
* Cross Sectional			GP	0/00/00	01	12/06/06	12/06/06	0/00/00	
* 3196 Pump Instruction Manuals			GP	0/00/00	01	12/06/06	12/06/06	0/00/00	
* Plan 53 With Finned Tubing			GP	0/00/00	01	12/06/06	12/06/06	0/00/00	
Seal Documents Required									
* Seal Drawing			GP	0/00/00	01	12/06/06	12/06/06	0/00/00	
Motor Documents Required									
* Motor Outline			GP	0/00/00	01	12/06/06	12/06/06	0/00/00	
* Motor Wiring Diagram			GP	0/00/00	01	12/06/06	12/06/06	0/00/00	
* Motor Electrical/Performance			GP	0/00/00	01	12/06/06	12/06/06	0/00/00	
* Motor Instructions-(Reliance)			GP	0/00/00	01	12/06/06	12/06/06	0/00/00	
Q.A. Documents Required									
* Comp. Hydrostatic Test Report			GP	0/00/00	01	12/06/06	12/06/06	0/00/00	
Tank Data Required									
Tank Drawing			GP	0/00/00	01	12/06/06	0/00/00	0/00/00	

(\*) Denotes Documents in this Submittal.

Your complete Approval is required before order is scheduled and released to manufacturing. Please forward Approval by / / .

The above literature is for your information and records. It does not requires your approval. Retain literature as your final distribution.

Note: Any Changes may affect Quoted Price and Shipping Details.

**06018**  
**CIE: EITANO**  
**RECEIVED DEC 13 2006**

**17.1**  
**PC-4105**  
**0180013048**

All dimensions are in inches.  
Drawing is not to scale  
Weights (lbs) are approximate

SUPERSEDES ANY PREVIOUS DRAWINGS

DRAWING NO A7295100 Rev. 0 Date: December 6, 2006

Customer: LURGI PSI, INC.  
Goulds Serial No: 729F510  
Customer P.O. No: 6018-70901  
Item No: PC-4105  
Service: BEER COLUMN FEED PUMP  
End User: CENTRAL ILLINOIS ENERGY L.L.C.  
Project No: 2003-01  
Location: CANTON, ILLINOIS

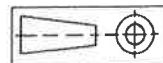

Joyce Sutterby

DATE December 6, 2006

DIMENSIONS ARE CERTIFIED FOR CONSTRUCTION BY:

(\*) Baseplate is sized to accommodate 364T/364TS/365T/365TS future motor size

MECH SEAL JOHN CRANE - 5620PR - X(18)O(58)1X(18)O(58)H / XF(55)1XO(58)H
BASEPLATE CAST IRON CAMBER TOP D00055A (*)
CPL GUARD BY PUMP MFG. CPLG GUARD MATL CARBON STEEL
COUPLING BY PUMP MFG. CPLG TYPE REXNORD OMEGA REX ELASTOMER-ES-20 (STAND

Auxiliary specification

MOTOR BY PUMP MFG. MOUNT BY PUMP MFG. MFG. RELIANCE
FRAME 326T POWER 30.0 hp RPM 1200
PHASE 3 FREQUENCY 60 HZ VOLTS 460
INSULATION F S.F. 1.15
ENCLOSURE FCXP-XEXCLASS 1 DIV 1 (CLASS 1 GRP D CLASS 2 GRPS F&G) T3C

Motor specification

FOR PUMP TAPPED OPENINGS REFER TO DWG. A729510T
MTR DIMENSIONS ARE APPROXIMATE
- INSTALL FOUNDATION BOLTS IN PIPE SLEEVES
- ALLOW FROM 0.75 to 1.50in. FOR GROUTING. SEE INSTRUCTION BOOK FOR DETAILS.
*Tolerance is +0.38 -0

Notes and References

SUCT FLANGE SIZE 6" DRILLING ANSI 150# FACING FF FINISH SERATED
DISCH FLANGE SIZE 4" DRILLING ANSI 150# FACING FF FINISH SERATED
PUMP ROTATION (LOOKING AT PUMP FROM MOTOR) CW
TYPE OF LUBRICATION FLOOD OIL
TYPE OF STUFFING BOX TAPER BORE PLUS WITH VPE
TYPE OF SEALING MECHANICAL SEAL

Pump specification

PUMP 520.0 lb
MOTOR/CPLG 580.0/18.0 lb
BASEPLATE 400.0 lb
TOTAL 1,518.0 lb
GR.VOLUME W/BOX 53.9 ft <sup>3</sup>
GR.WEIGHT W/BOX 1,788.0 lb

Weights and Measurements

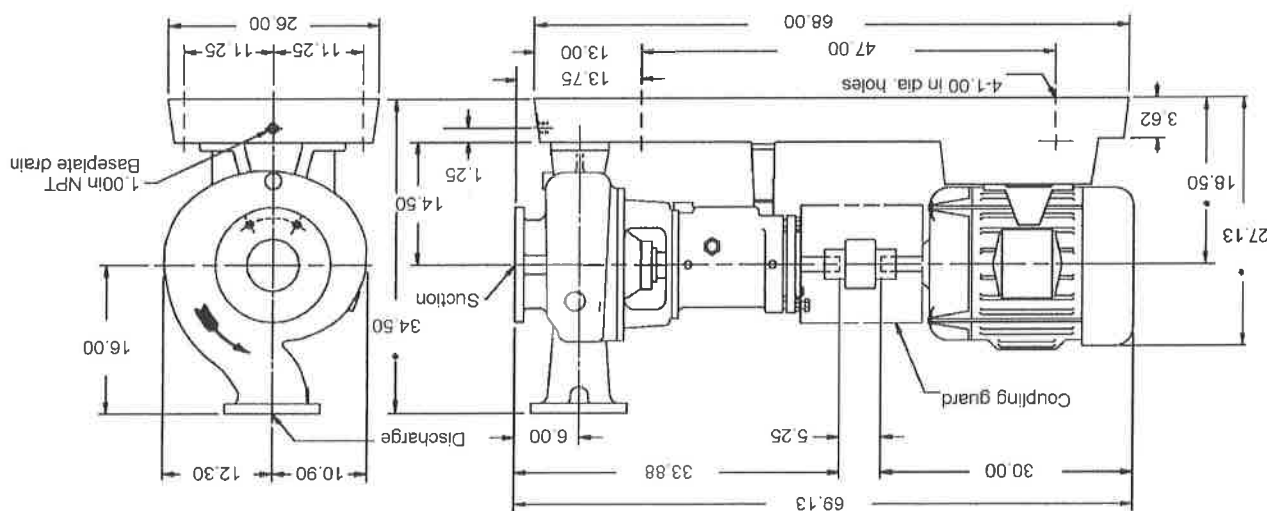

All dimensions are in inches.  
Drawing is not to scale.

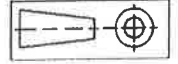

SUPERSEDES ANY PREVIOUS DRAWINGS

**DRAWING NO** A729510T **Rev. 0** Date: December 6, 2006

Customer: LURGI PSI, INC.  
Goulds Serial No: 729F510  
Customer P.O. No: 6018-70901  
Item No: PC-4105  
Service: BEER COLUMN FEED PUMP  
End User: CENTRAL ILLINOIS ENERGY L.L.C.  
Project No: 2003-01  
Location: CANTON, ILLINOIS

**Joyce Suterby**  
DIMENSIONS ARE CERTIFIED FOR CONSTRUCTION BY:  
DATE December 6, 2006

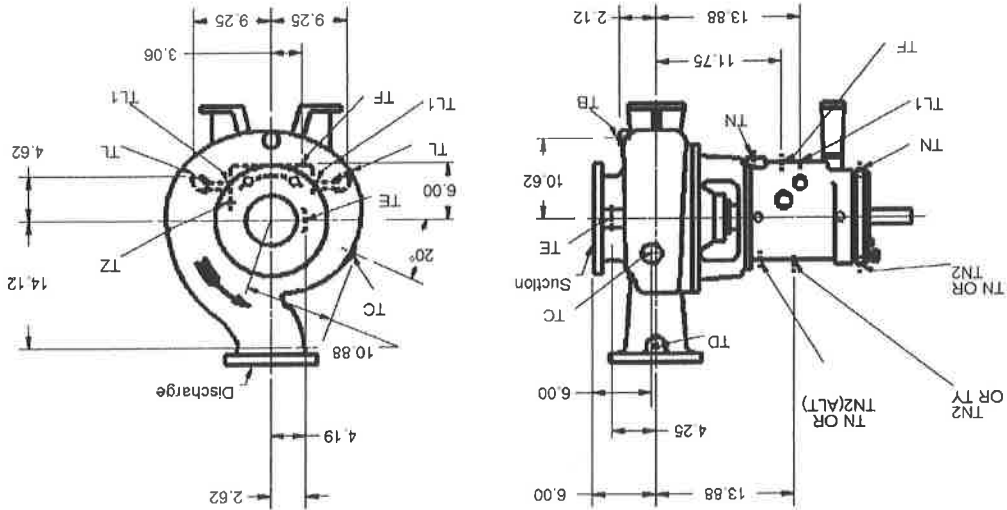

NO.	SIZE	QTY.	PURPOSE	YES/NO	NO.	SIZE	QTY.	PURPOSE	YES/NO
TB	1/2	1	CASING DRAIN	YES	TL1	---	2	FRAME COOLER ACCESS	YES
TC	1/2	1	BY-PASS CONNECTION	NO	TN	1/4	4	GREASE FITTING	YES
TD	3/8	1	DISCH. GAUGE CONNECTION	NO	TN2	1/4	2	OIL MIST INJECTION PORT	YES
TE	3/8	1	SUCTION GAUGE CONNECTION	NO	TY	1/2	1	OIL FILL	YES
TF	3/8	1	BEARING FRAME DRAIN	YES	TZ	1/4	1	BOTTLE OILER CONN.	YES
TL	1/2	2	FRAME COOLING CONNECTION	NO	TBL	1/4	2	VIB./TEMP. CONN.	YES

TAPPED OPENINGS MODEL 3196 X17 4x6-17 A.N.S.I.NO.

FURNISHED

FURNISHED





**CENTRIFUGAL PUMP CHARACTERISTICS**

**CDS 4358-2**  
**RPM 1180**

Model: 3196  
Size: 4X6-17  
Imp. Dwg: D04563A  
Pattern: 68003 / 68015  
Eye Area: 38.5 in<sup>2</sup>

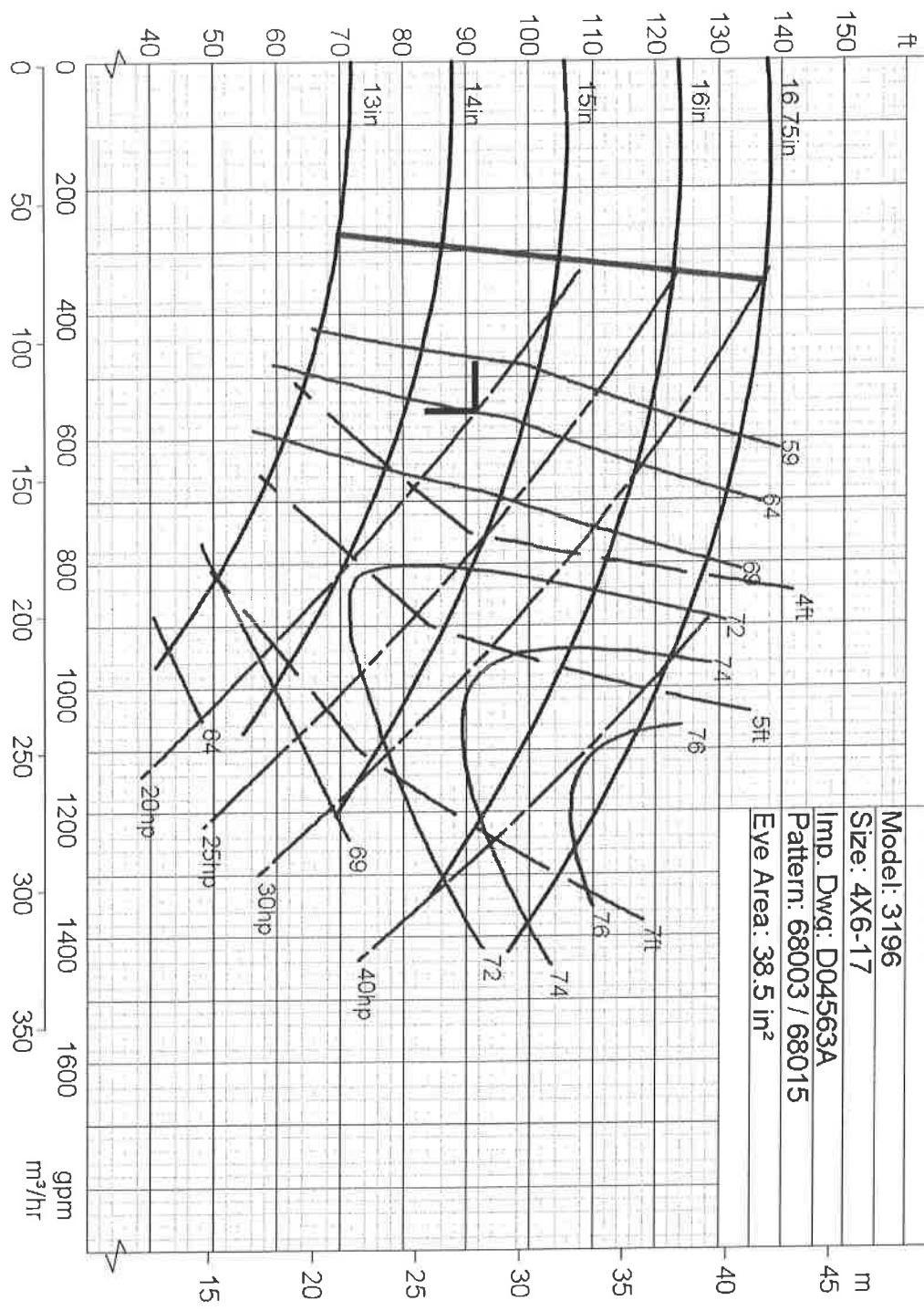

Rated Flow: 560.0 gpm  
Rated TDH: 90.0 ft  
Imp. Diam.: 14.6250 in  
Certified By: Andrew Young

Customer: LURGI PSI, INC  
Goulds Serial No: 7295510  
Customer P.O. No: 601870901  
Item No: PC-4105  
Service: BEER COLUMN FEED PUMP  
End User: CENTRAL ILLINOIS ENERGY LLC  
Project No: 2003-01  
Location: CANTON, ILLINOIS

