

XP-12 STANDARD/EZview Loading Spout
 - General Specifications -

The XP-12 STANDARD/EZview Bulk Loading Spout is designed to provide Dust-Free loading (410 CFM Maximum Loading Capacity) of dry bulk materials into hatched trucks and railcars. The dust generated during loading is withdrawn from the point of discharge and through the annular passage between the product guide cones and the ROADSTAR 18® shroud. Once inside this passage, the velocity of the air stream decreases. This allows the relatively dense particulate to be drawn back into the gravity fed product stream. Extremely fine particulate continues through the negative air connection and into the user's ventilation system. For adequate ventilation, we recommend 900-1200 CFM of negative air.

- Standard Features -

- 1.1 Non-contact components of 12 gauge carbon steel.
- 1.2 Up to 20 feet of Vertical Travel.
- 1.3 Flat-Faced product inlet ~ 18" diameter with blind flange for field adaptation.
- 1.4 75 degree sloped product inlet chute transition.
- 1.5 10" diameter flat-faced negative air connection.
- 1.6 5/16" thick molded urethane internal self-stacking product guide cones.
- 1.7 Flexible "ROADSTAR 18®" shroud with internal galvanized steel reinforcing rings.
- 1.8 Heavy duty worm gear reducer with 1 HP ~ 1800 RPM ~ TEFC motor for cable hoist drive. (3/60/230-460VAC)
- 1.9 Double sprocket and chain drive. (not shown)
- 1.10 Full-Up and Full-Down rotary limit switch. (not shown)
- 1.11 All standard (and optional) electrical features factory wired to a J.I.C. junction box.
- 1.12 Three cable hoist and drive enclosed with guard and dust cover.
- 1.13 Loading spout is factory assembled, wired, inspected and tested then skidded and crated for ease of shipment and installation.
- 1.14 Unit to be supported from Support Mounting Angles (By Others).

- Optional Features -

- 2.1 Product Inlet ~ Raised-Face A.N.S.I. drilled flanges
 10" 12" 14" 16" Diameter
- 2.2 Electrical Controls
 Operator's control pendent in a NEMA 4x enclosure.
 Slack Cable limit switches.
 Mercury level sensor with control logic enclosure.
 Capacitance level sensor with control logic enclosure.
 Explosion Proof/Intrinsically Safe.
- 2.3 Metal Inner Chute
 10 ga. 304SS or 316SS
 10 ga. mild steel
 3/16" thick Abrasion Resistant Steel
- 2.4 Metal Inner Cones
 10 ga. 304SS or 316SS
 10 ga. mild steel
 3/16" thick Abrasion Resistant Steel
- 2.5 EZ view lower weldment assembly.
 Please Note: The use of the EZ view weldment increases the required negative air volume to 1200 - 1400 CFM.
- 2.6 Hypalon Shroud W/ S.S. Reinforcing Rings

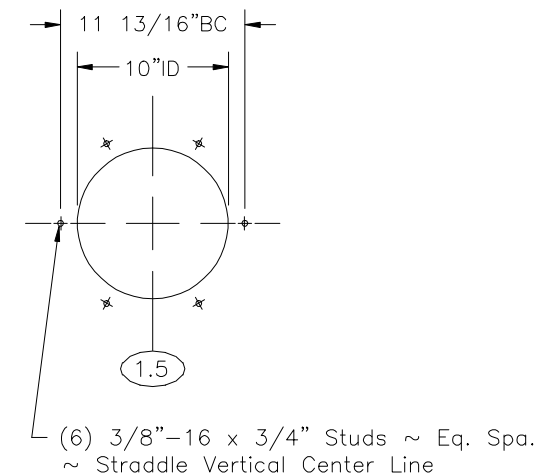
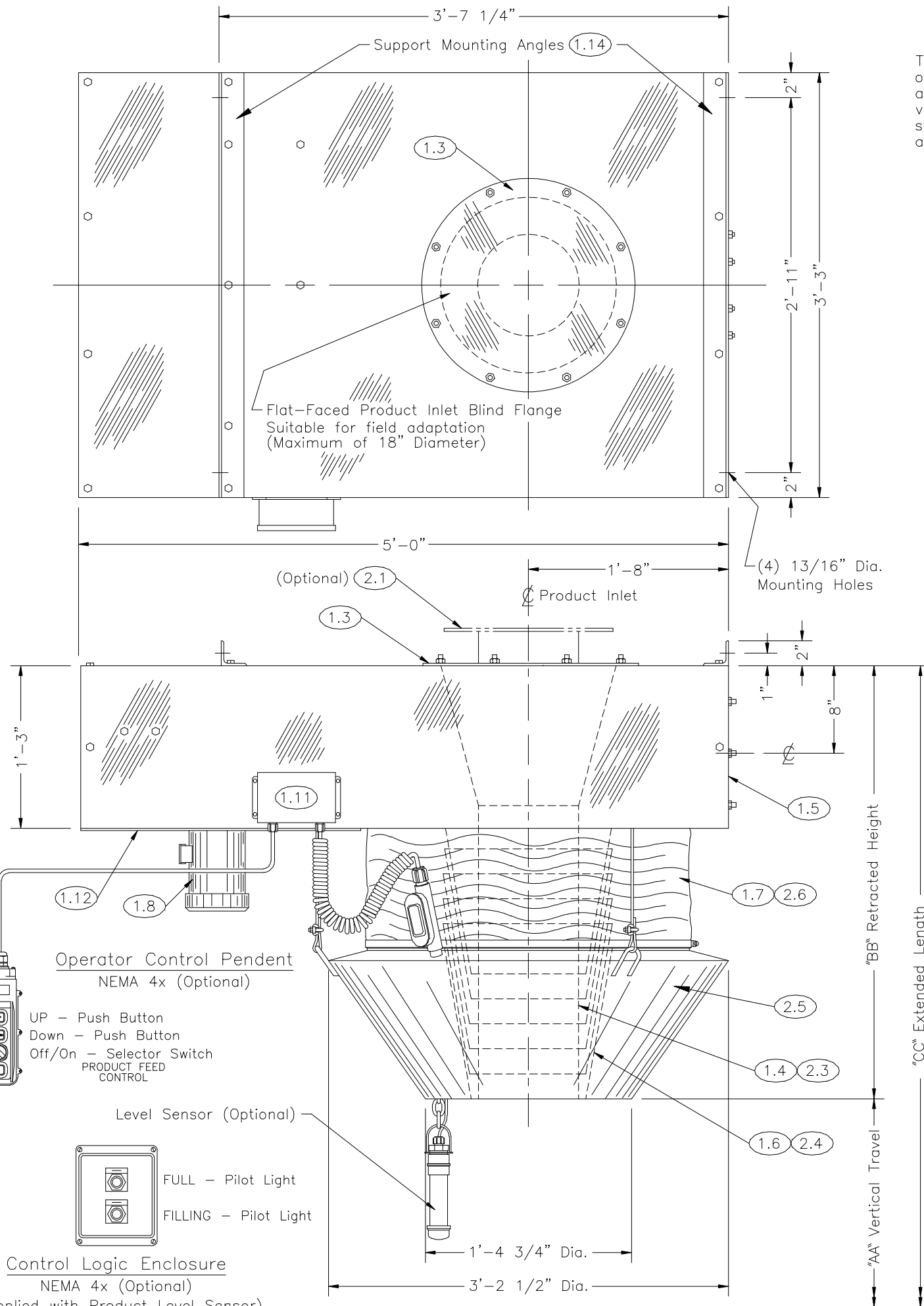

Negative Air Flange Detail

Product Inlet Raised Face Flange

(OPTIONAL)
A.N.S.I. Standard Drilling

Inlet Dia.	Bolt Circle	Outside Dia.	Hole Dia.	No. of Holes	Bolt Size
10"	14 1/4"	16"	1"	12	7/8"
12"	17"	19"	1"	12	7/8"
14"	18 3/4"	21"	1 1/8"	12	1"
16"	21 1/4"	23 1/2"	1 1/8"	16	1"

"AA" Vertical Travel	"BB" Retracted Height	"CC" Extended Length
8'-0"	2'-9"	10'-9"
10'-0"	3'-2"	13'-2"
12'-0"	3'-4"	15'-4"
14'-0"	3'-7"	17'-7"
16'-0"	3'-9"	19'-9"
18'-0"	4'-2"	22'-2"
20'-0"	4'-5"	24'-5"

NOT FOR CONSTRUCTION

(Date 6/25/98)

SLY INC. TECHNOLOGY FOR A CLEAN ENVIRONMENT

SLY Incorporated
 LOADING SPOUT & POSITIONER PRODUCTS
 8300 Dow Circle, Strongsville OH 44136
 (440)891-3200 * FAX:(440)891-3210

XP-12 Std/EZview Loading Spout

JOB: 3D-10528